

INOX | Upright Cabinets

REFRIGERATED CABINETS ▶ GN2/1-NO FROST ▶ FREEZER

QNG 14



DETAILS

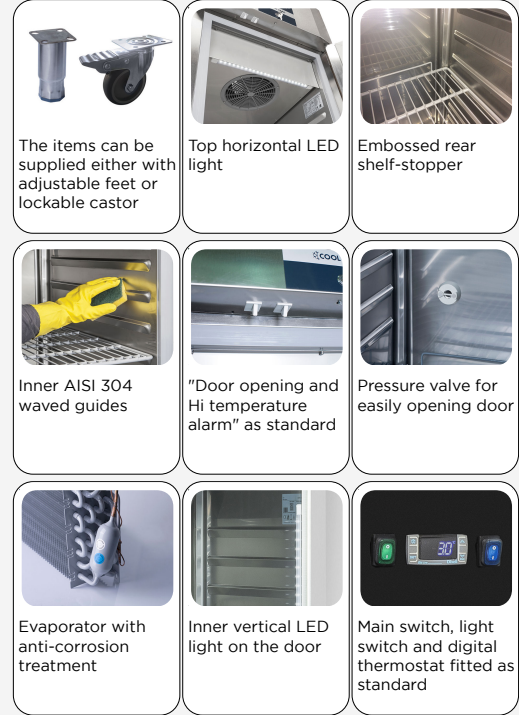

GENERAL FEATURES

- GN2/1 Freezer upright cabinet (GLASS DOOR)
- Stainless Steel exterior and interior
- Plastic thermal-braker as chamber body frame (Hot pipe system)
- Inner with embossed rear shelf stopper and wave for easy cleaning
- Ventilated Cooling
- Evaporator with anti-corrosion treatment
- Automatic defrost with electric heater
- Foaming Agent Cyclopentane (85mm)
- Digital thermostat with "opening door" and "Hi temperature" alarm
- Removable Gasket
- LED light and lock fitted as standard
- Door: Self closing and heated glass (Not reversable)
- Adjustable shelves GN2/1: 6 + 2 + 3 middle
- N.4 S/S Adjustable feet - (Lockable castor as Optional)
- Energy efficiency class: -

TECHNICAL SPECIFICATIONS

External Dimensions (WxDxH mm)	1430x918x2085
Internal Dimensions (WxDxH mm)	1260x665x1390
Noise level	62 dB(A)
Consumption	0 kWh/24h
Capacity	1105 L
Rated Power	700 W
Net Weight	271 Kg
Temperature	-15°C ~ -20°C
Gross Weight	306 Kg
Packaging dimensions (WxDxH mm)	1450x920x2150
Loading quantities 20'/40'/40'HQ	7/16/16

PRODUCT DIMENSIONS

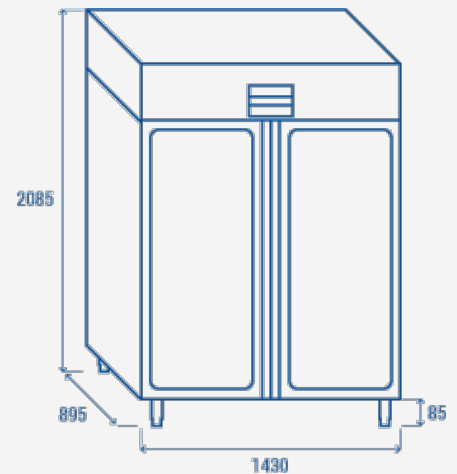

CERTIFICATION

CE RoHS

